

### 15. Making the table

Cut off the outside edges of the two bunk formers (T2) by extending the slots and glue to the base (T3) of the table top (T1) ensuring that an even margin is left on the forward and outer edges of the table to enable the table to locate between the bunk units. Attach the table to the support with 3 No.  $\frac{3}{4}$ " No.6 wood screws.

### 16. Outboard motor pad

This is made from five pieces of 9mm ply which are part of your wood pack. Glue the three pieces (M1) together and then glue on the two pieces (M2) on the outside having first faired the inner edges of the outer faces to fit the GRP moulding. The chock is fitted to the boat by using Ryplas bonding mix. This will ensure the chock fits firmly to the GRP moulding. Lastly screw the top plate (M3) into position as shown in Fig.7.

### 17. King post

Before attaching the mast step fitting to the deck drill the two forward bolt holes to align the king post top capping. The king post may need trimming accurately to length to ensure that there is no play in the end fittings. If the table is being

fitted the support with the table top attached should be slid down the king post to the level of the bunk units and the bottom of the table levelled with them by moving the bottom of the king post if necessary. The top capping piece may now be bolted through the deck to the mast step and the bottom fitting secured with 4 No.  $1\frac{1}{2}$ " x 8 wood screws. Be especially careful when drilling the pad in the bottom of the boat not to go too far as you may end up by drilling right through the hull. Finally drill through both the top capping and the king post and secure with a small self tapping screw to prevent the table from turning the post. Fig.11.

### 18. Interior Finish

Having completed the construction of your boat you can now add extra coats of varnish to the exposed wooden surfaces.

The interior surfaces may be finished with an anti-condensation paint similar to International Paints "Korkon", or alternatively they may be covered with one of the many foam filled materials available in D.I.Y. shops. For a really luxurious look an inexpensive carpeting is really effective.

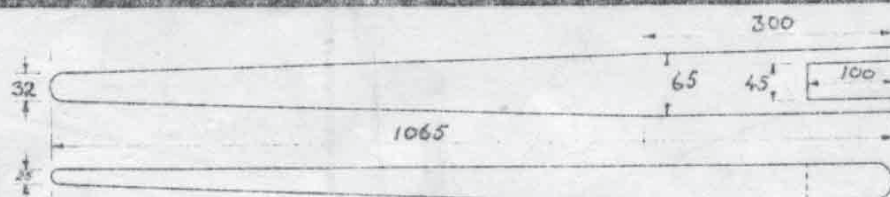

FIG. 9.

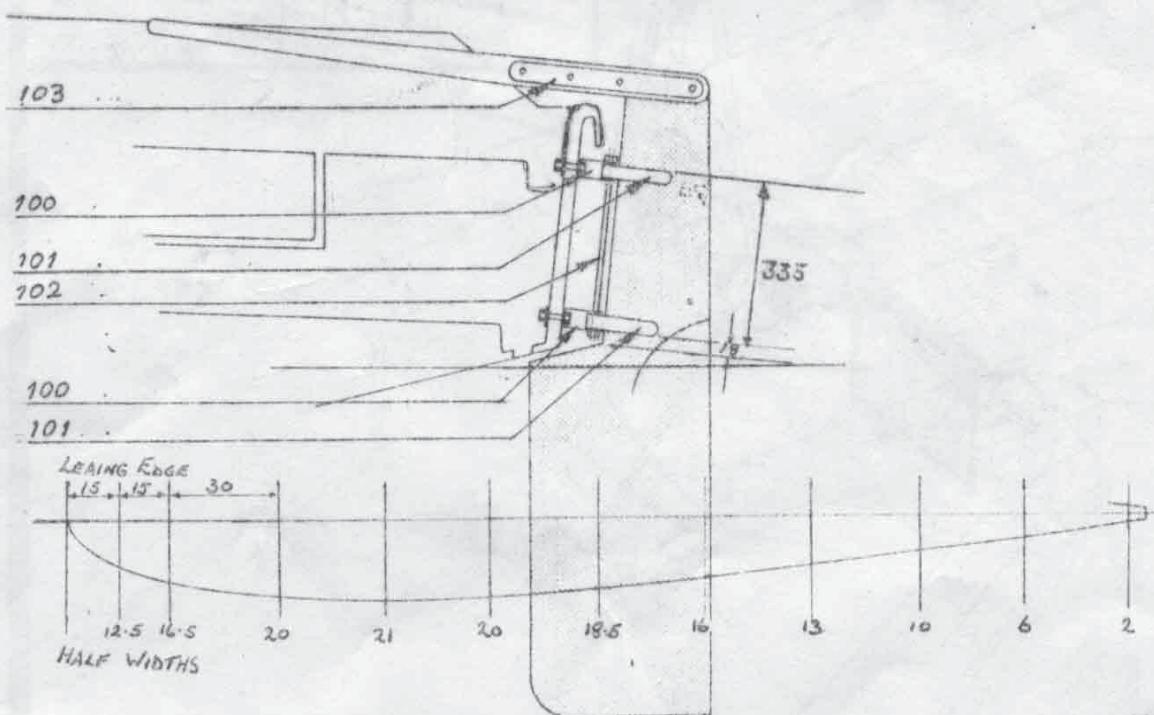

FIG. 10.



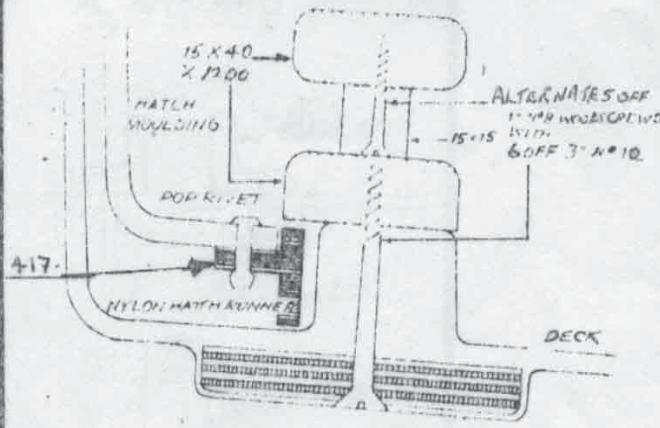

FIG. 3.

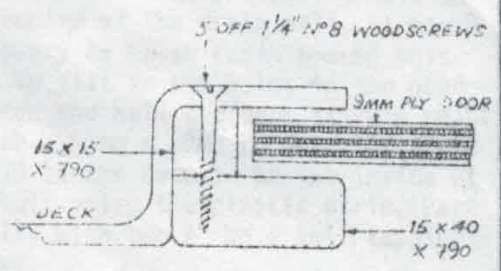

FIG. 4.

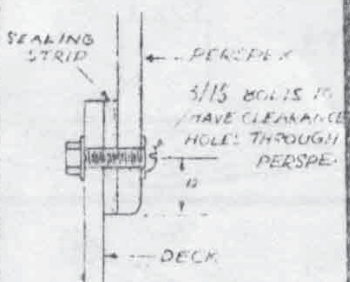

FIG. 5.

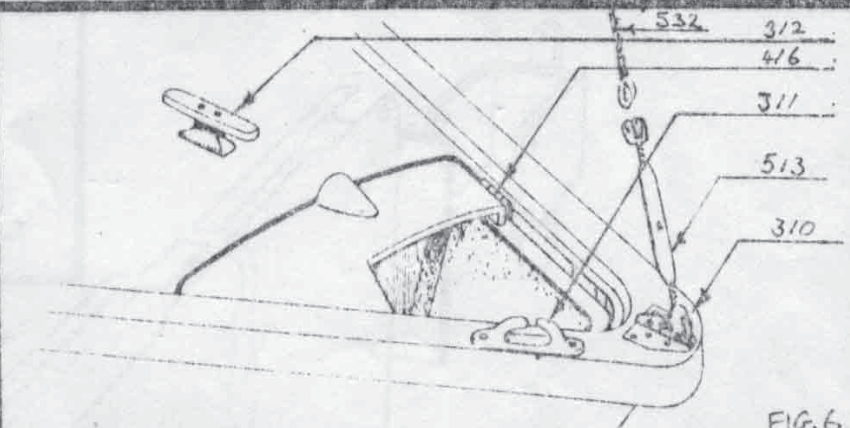

FIG. 6.

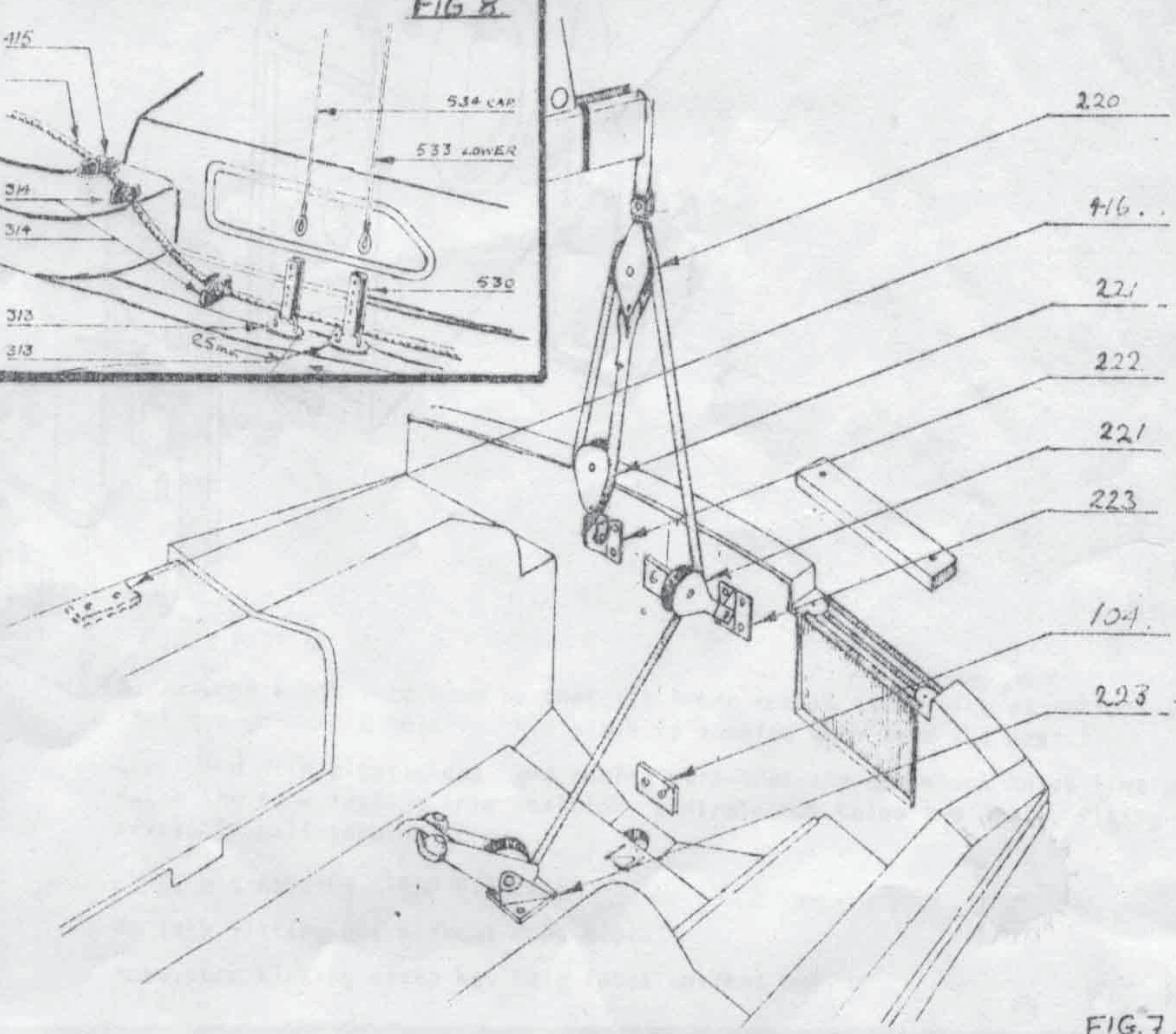
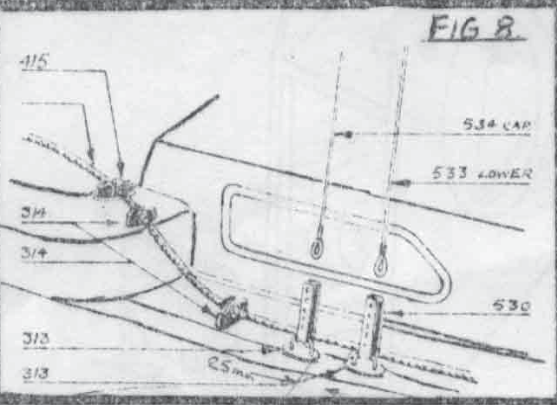

FIG. 7.